



FLEXURE BEARING PULSE TUBE COOLER SF100PT

- **Outstanding specific performance**
- **High reliability (Lifetime >60,000h)**
- **Compact Pulse Tube Design**
- **Ideal cooler for 24/7 applications**
- **Very low vibration output**
- **Inaudible**

The AIM SF100PT is a Pulse Tube Cryocooler based on Moving Magnet Technology and Flexure Bearing suspension to support the driving mechanism. A computerized alignment process combined with an optimized material composition inside the helium vessel results in lifetimes exceeding 60,000 hours.

The SF100PT is compact and light weight, and provides a cooling capacity of up to 1W@80K (23°C). With its high specific cooling performance and outstanding reliability, the SF100PT is the ideal cryocooler for IR-detectors as well as commercial and scientific detector devices operating 24/7.

The cooler can be used with AIM's digital high efficient cooler control electronics DCE100 or can alternatively be operated with customer's electronics. For the application of a cooler vibration control both motor drives can be operated separately.

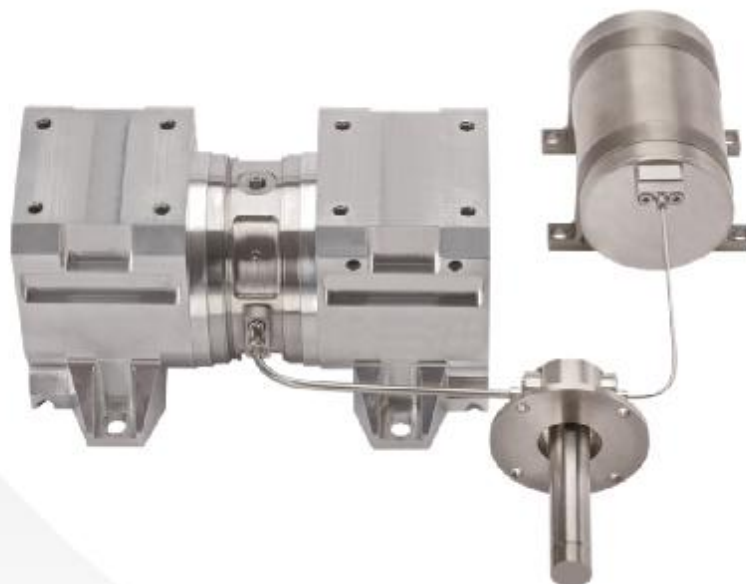

Typical Performance Data SF100PT @ 23°C

Applications

- 24/7 Devices
- Space and Airborne Systems
- Scientific Instruments
- IR-Surveillance Equipment
- Ambient temperature at -40°C to +60°C

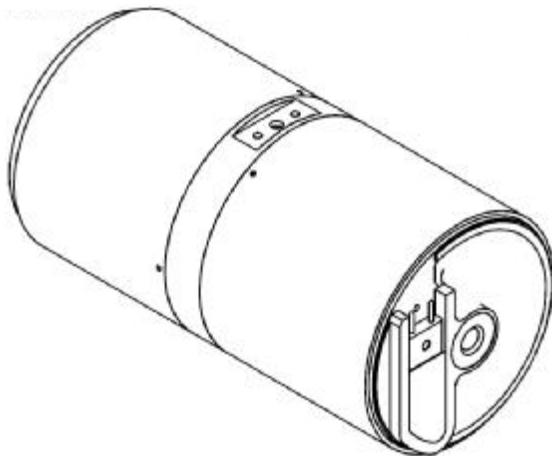
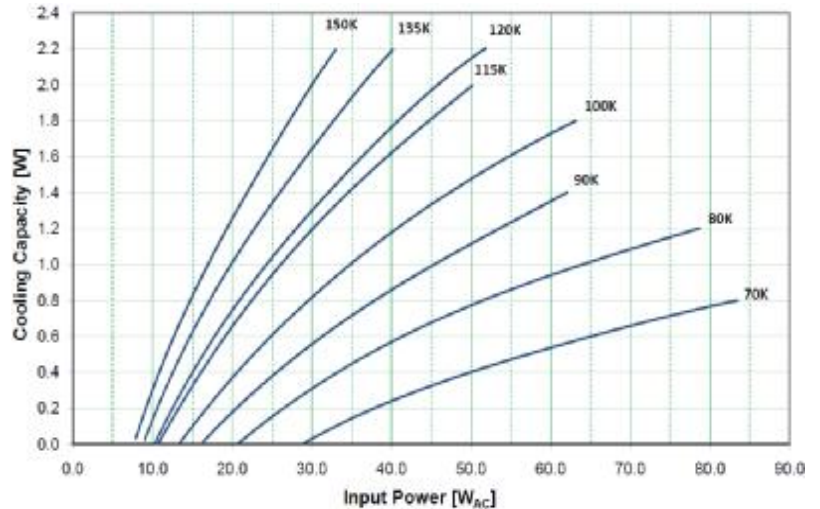

SF100 compressor (standard)

	SF100PT
Compressor dimensions [mm]	122 x 60
Cryocooler weight [kg] (including Pulse Tube & Buffer)	3.0
Supply voltage [V _{AC}]	6 - 17
Cooler controller	AIM DCE100 or customer controller
Coldtip I/F	clamp or thread hole
Ambient temperature range [°C]	-40 to +60

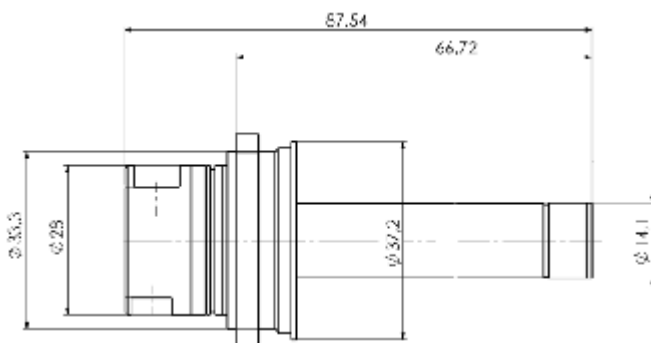

Dimensions of standard Pulse Tube Coldfinger

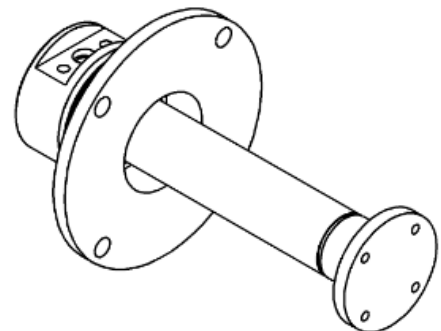

Coldfinger I/F's with cold tip mounting threads for connecting copper thermal mass or strap and vacuum flange for active vacuum pumping (optional)

AIM INFRAROT-MODULE GmbH
 Theresienstraße 2
 D 74072 Heilbronn / Germany
 Tel.: +49 7131 6212 - 310
 Fax: +49 7131 6212 - 399
CoolersAIM@aim-ir.com
www.aim-ir.com